

Tavola riassuntiva delle principali caratteristiche costruttive e di funzionamento / Main fabrication and operating characteristics table

con anello di regolazione / with adjusting ring  
(conforme allo std./according to API 526)

Mod.	Tipo di cappello	Certificati	Conessioni
<b>291</b> con bocchaglio pieno e anello di regolazione	Cappello chiuso (molla coperta)	PED-ATEX	Conessioni Std. flangiate ANSI B16.5 (per esecuzioni diverse, fare riferimento all'Ufficio Tecnico)
<b>292</b> con bocchaglio pieno e anello di regolazione	Cappello aperto (molla scoperta)	PED	

Type	Bonnet type	Certifications	Connections
<b>291</b> full nozzle and adjusting ring	Closed (covered spring)	PED-ATEX	Std. connections flanged ANSI B16.5 (for different executions please refer to Technical Dept.)
<b>292</b> full nozzle and adjusting ring	Open (Uncovered spring)	PED	

## Principali caratteristiche funzionali

Applicazioni	Aeriformi	Liquidi
Campo pressioni di taratura p:	da 0.5 a 300 barg	da 0.5 a 300 barg
<b>Materiali di costruzione di corpo e cappello</b>		<b>Interv. temp. di esercizio*</b>
Corpo e cappello in acciaio al carbonio		da -20 a +426°C
Corpo e cappello in acciaio basso legato Cr Mo		da -20 a +538°C
Corpo e cappello in acciaio inossidabile		da -196 a +538°C

\* Per temperature e pressioni diverse da quelle riportate nella presente tabella, fare riferimento all'Ufficio Tecnico.

Coeff. di efflusso equivalenti	Aeriformi	Liquidi
Kd	0.975	0.65

	Aeriformi	Liquidi
<b>Sovrapressione</b>	+10% se $p \geq 1$ bar +0.1 bar se $p < 1$ bar	+10% se $p \geq 1$ bar +0.1 bar se $p < 1$ bar
<b>Scarto di chiusura</b>	-10% 0.1 bar se $p < 1$ bar -0.1 bar se $p < 1$ bar	-20% di p -0.2 bar se $p < 1$ bar

## Massima contropressione pb ammessa generata pb

Valvola senza soffiato di bilanciamento	10% della press. di taratura aeriformi 20% della press. di taratura liquidi
Valvola con soffiato di bilanciamento	40% della press. di taratura

Per l'impiego di valvole in contropressione (pb) imposta fare riferimento all'Ufficio Tecnico.

## Main operating characteristics

Applications	Gaseous	Liquid
Set pressure range p:	from 0.5 to 300 barg	from 0.5 to 300 barg
<b>Body and bonnet construction material</b>		<b>Temperature Range*</b>
Carbon steel body and bonnet		from -20 to +426°C
Cr Mo Alloy steel body and bonnet		from -20 to +538°C
Stainless steel body and bonnet		from -196 to +538°C

\* For temperature and pressure different than those in this table, ask to Technical Department.

Effective coeff. of discharge	Gaseous	Liquid
Kd	0.975	0.65

	Gaseous	Liquid
<b>Overpressure</b>	+10% if $p \geq 1$ bar +0.1 bar if $p < 1$ bar	+10% if $p \geq 1$ bar +0.1 bar if $p < 1$ bar
<b>Blow down</b>	-10% 0.1 bar if $p < 1$ bar -0.1 bar if $p < 1$ bar	-20% of p -0.2 bar if $p < 1$ bar

## Maximum allowable builtup back pressure pb

Safety valves without balancing bellow	10% of set pressure gas and vapour 20% of set pressure liquid
Safety valves with balancing bellow	40% of set pressure

In case of superimposed backpressure, please refer to Technical Department.

LEGENDA: p= pressione di taratura (barg); pb= contropressione (barg).

LEGENDA: p=set pressure (barg) pb= backpressure (barg)

## Note

Alcuni dati riportati nella presente pagina possono variare su specifica richiesta, previa analisi e approvazione delle funzioni competenti di Besa S.p.A.

## Note

Some information given on these pages can be changed upon specific requests, after BESA qualified office approval.

## Legenda materiali std.

Descrizione	291-C / 292-C Valvola con corpo in acciaio al carbonio	291-L / 292-L Valvola con corpo in acciaio legato	291-I Valvola con corpo in acciaio inossidabile
1 Corpo Valvola	Acciaio al Carbonio ASTM A216 WCB - EN 1.0619	Acciaio legato ASTM A217 WC6 - EN 1.7357	Acciaio inossidabile ASTM A351 CF8M - EN 1.4408
2 Boccaglio	Acciaio inossidabile ASTM 316 - EN 1.4401	Acciaio inossidabile ASTM 316 - EN 1.4401	Acciaio inossidabile ASTM 316 - EN 1.4401
2a Anello di regolazione	Acciaio inossidabile ASTM 316 - EN 1.4401 - ASTM 420 - EN 1.4028	Acciaio inossidabile ASTM 316 - EN 1.4401 - ASTM 420 - EN 1.4028	Acciaio inossidabile ASTM 316 - EN 1.4401
3 Otturatore	Acciaio inossidabile ASTM 420 - EN 1.4028 o ASTM 316 - EN 1.4401	Acciaio inossidabile ASTM 420 - EN 1.4028 o ASTM 316 - EN 1.4401	Acciaio inossidabile ASTM 316 - EN 1.4401
4 Sfera	Acciaio inossidabile ASTM 420 - EN 1.4028 o ASTM 316 - EN 1.4401	Acciaio inossidabile ASTM 420 - EN 1.4028 o ASTM 316 - EN 1.4401	Acciaio inossidabile ASTM 316 - EN 1.4401
5 Piattello Guida	Acciaio al carbonio con bussola ASTM 430F tenifer o Acciaio inossidabile ASTM 316 - EN 1.4401	Acciaio al carbonio con bussola ASTM 430F tenifer o Acciaio inossidabile ASTM 316 - EN 1.4401	Acciaio inossidabile ASTM 316 - EN 1.4401
6 Ralla Molla	AVP 1.0737 o Acciaio inossidabile ASTM 316 - EN 1.4401	AVP 1.0737 o Acciaio inossidabile ASTM 316 - EN 1.4401	Acciaio inossidabile ASTM 316 - EN 1.4401
7 Asta	Acciaio inossidabile ASTM 430F - EN 1.4104 o ASTM 316 - EN 1.4401	Acciaio inossidabile ASTM 430F - EN 1.4104 o ASTM 316 - EN 1.4401	Acciaio inossidabile ASTM 316 - EN 1.4401
8 Molla	Acciaio al carbonio Acciaio legato	Acciaio al carbonio Acciaio legato	Acciaio inossidabile ASTM 316 S42
9 Vite di regolazione	Acciaio AVP o Acciaio inossidabile ASTM 316 - EN 1.4401 con bussola in PTFE	Acciaio AVP o Acciaio inossidabile ASTM 316 - EN 1.4401 con bussola in PTFE	Acciaio inossidabile ASTM 316 - EN 1.4401 con bussola in PTFE
10 Cappello	Acciaio al Carbonio ASTM A216 WCB - EN 1.0619	Acciaio al Carbonio ASTM A216 WCB - EN 1.0619	Acciaio inossidabile ASTM A351 CF8M - EN 1.4408
11 Cappuccio H4 a tenuta con leva	Acciaio al Carbonio ASTM A216 WCB - EN 1.0619	Acciaio al Carbonio ASTM A216 WCB - EN 1.0619	Acciaio inossidabile ASTM A351 CF8M - EN 1.4408

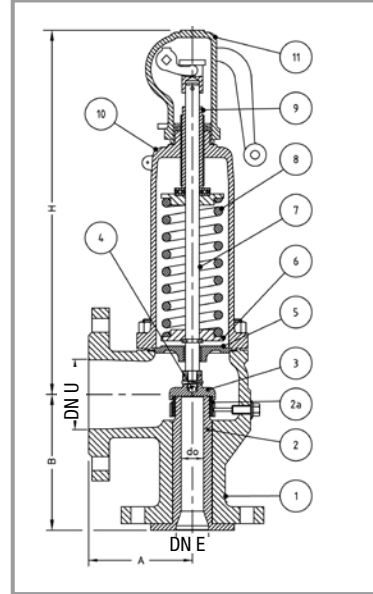

## Cappucci

Cappuccio tipo H2, a tenuta senza leva di sollevamento

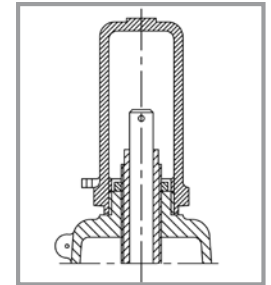

Cappuccio tipo H3, aperto con leva di sollevamento dell'otturatore

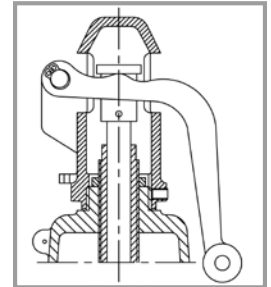

Cappuccio H4, a tenuta con leva di sollevamento dell'otturatore

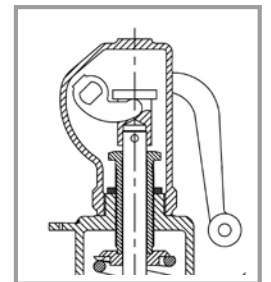

## Dimensioni scartamenti - classificazione flange entrata x uscita

DN E	Orifizio	ASME CL 150 x 150		ASME CL 300 x 150		ASME CL 600 x 150		ASME CL 900 x 150		ASME CL 900 x 300		ASME CL 1500 x 150		ASME CL 1500 x 300		ASME CL 2500 x 300		H mm
		A mm	B mm	A mm	B mm	A mm	B mm	A mm	B mm	A mm	B mm	A mm	B mm	A mm	B mm	A mm	B mm	
1"x2"	D/E	114.3	104.8	114.3	104.8	114.3	104.8											320
1 1/2 x 2"	D									139.7	104.8			139.7	104.8			350
	E									139.7	104.8			139.7	104.8			
	F	120.7	123.8	120.7	123.8	152.4	123.8											
1 1/2 x 3"	D															177.8	139.7	350
	E															177.8	139.7	
	F									165.1	123.8			165.1	123.8	177.8	139.7	
	G	120.7	123.8	120.7	123.8	152.4	123.8			165.1	123.8							
	H	123.8	130.2	123.8	130.2													
2" x 3"	G													171.4	155.5	171.4	155.5	400
	H			123.8	130.2	161.9	153.9	161.9	153.9					161.9	153.9			
	J	123.8	136.5	123.8	136.5													
3" x 4"	J			180.9	184.1	180.9	184.1	180.9	184.1					180.9	184.1			420
	K	161.9	155.6	161.9	155.6	180.9	184.1											
3" x 6"	L							215.9	198.4					215.9	196.9			420
	K																	
4" x 6"	L			181	179.4	181	179.4	222.3	196.9			222.3	196.9					680
	M	184.2	117.8	184.2	177.8	203.2	177.8	222.3	196.9									
	N	209.6	196.9	209.6	196.9	222.3	196.9	222.3	196.9									
	P	228.6	181	228.6	181	254	225.4	254	225.4									
6" x 8"	Q	241.3	239.7	241.3	239.7	241.3	239.7											700
	R	241.3	239.7	241.3	239.7													
6" x 10"	R					266.7	239.7											700
8" x 10"	T	279.4	276.2	279.4	276.2													1000

dimensioni indicative, da confermare in caso di ordine

A richiesta e con l'approvazione dell'Ufficio Tecnico, la costruzione delle valvole può essere eseguita utilizzando componenti di materiale diverso da quello indicato nella tabella soprastante.

## Std. material legenda

Description	291-C / 292-C Valve with carbon steel body	291-L / 292-L Valve with alloy steel body	291-I Valve with stainless steel body
1 Valve body	Carbon steel ASTM A216 WCB - EN 1.0619	Alloy steel ASTM A217 WC6 - EN 1.7357	Stainless steel ASTM A351 CF8M - EN 1.4408
2 Full nozzle (seat)	Stainless steel ASTM 316 - EN 1.4401	Stainless steel ASTM 316 - EN 1.4401	Stainless steel ASTM 316 - EN 1.4401
2a Adjusting ring	Stainless steel ASTM 316 - EN 1.4401 - ASTM 420 - EN 1.4028	Stainless steel ASTM 316 - EN 1.4401 - ASTM 420 - EN 1.4028	Stainless steel ASTM 316 - EN 1.4401
3 Disc	Stainless steel ASTM 420 - EN 1.4028 or ASTM 316 - EN 1.4401	Stainless steel ASTM 420 - EN 1.4028 or ASTM 316 - EN 1.4401	Stainless steel ASTM 316 - EN 1.4401
4 Ball	Stainless steel ASTM 420 - EN 1.4028 or ASTM 316 - EN 1.4401	Stainless steel ASTM 420 - EN 1.4028 or ASTM 316 - EN 1.4401	Stainless steel ASTM 316 - EN 1.4401
5 Guide	Carbon steel with bush ASTM 430F tenifer or Stainless steel ASTM 316 - EN 1.4401	Carbon steel with bush ASTM 430F tenifer or Stainless steel ASTM 316 - EN 1.4401	Stainless steel ASTM 316 - EN 1.4401
6 Spring plate	AVP steel or Stainless steel ASTM 316 - EN 1.4401	AVP steel or Stainless steel ASTM 316 - EN 1.4401	Stainless steel ASTM 316 - EN 1.4401
7 Spindle	Stainless steel ASTM 430F - EN 1.4104 or ASTM 316 - EN 1.4401	Stainless steel ASTM 430F - EN 1.4104 or ASTM 316 - EN 1.4401	Stainless steel ASTM 316 - EN 1.4401
8 Spring	Carbon steel Alloy steel	Carbon steel Alloy steel	Stainless steel ASTM 316 S42
9 Pressure adjusting screw	AVP steel or Stainless steel ASTM 316 - EN 1.4401 with bush PTFE	AVP steel or Stainless steel ASTM 316 - EN 1.4401 with bush PTFE	Stainless steel ASTM 316 - EN 1.4401 with bush PTFE
10 Bonnet	Carbon steel ASTM A216 WCB - EN 1.0619	Carbon steel ASTM A216 WCB - EN 1.0619	Stainless steel ASTM A351 CF8M - EN 1.4408
11 Tight cap H4 with lifting lever	Carbon steel ASTM A216 WCB - EN 1.0619	Carbon steel ASTM A216 WCB - EN 1.0619	Stainless steel ASTM A351 CF8M - EN 1.4408

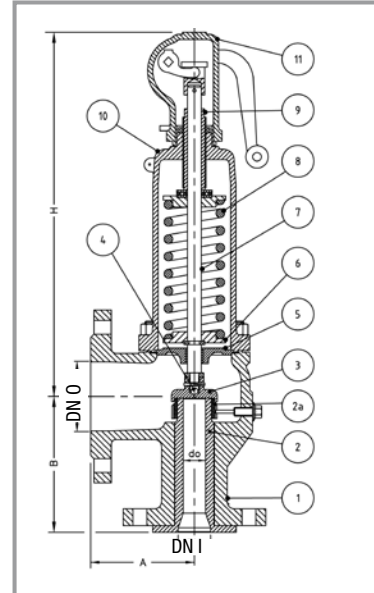

## Caps

Tight Cap H2 without lifting lever

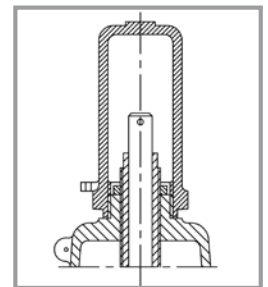

Open Cap H3 with plain lifting lever

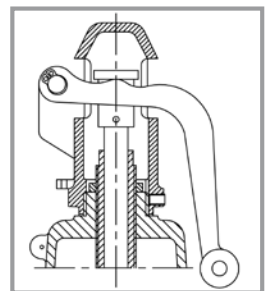

Tight cap H4 with packed lifting lever

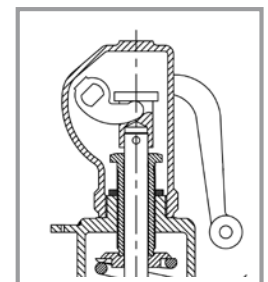

## Inlet x outlet flange ratings

DN I	Orifice	ASME CL 150 x 150		ASME CL 300 x 150		ASME CL 600 x 150		ASME CL 900 x 150		ASME CL 900 x 300		ASME CL 1500 x 150		ASME CL 1500 x 300		ASME CL 2500 x 300		H mm		
		A mm	B mm	A mm	B mm	A mm	B mm	A mm	B mm	A mm	B mm	A mm	B mm	A mm	B mm	A mm	B mm			
1"x2"	D/E	114.3	104.8	114.3	104.8	114.3	104.8											320		
1 1/2 x 2"	D									139.7	104.8			139.7	104.8			350		
	E									139.7	104.8			139.7	104.8					
	F	120.7	123.8	120.7	123.8	152.4	123.8													
1 1/2 x 3"	D																177.8	139.7	350	
	E																177.8	139.7		
	F									165.1	123.8			165.1	123.8		177.8	139.7		
	G	120.7	123.8	120.7	123.8	152.4	123.8			165.1	123.8									
	H	123.8	130.2	123.8	130.2															
2" x 3"	G															171.4	155.5	171.4	155.5	400
	H			123.8	130.2	161.9	153.9	161.9	153.9					161.9	153.9					
	J	123.8	136.5	123.8	136.5															
3" x 4"	J			180.9	184.1	180.9	184.1	180.9	184.1					180.9	184.1				420	
	K	161.9	155.6	161.9	155.6	180.9	184.1													
3" x 6"	L																		420	
	K							215.9	198.4					215.9	196.9					
4" x 6"	L			181	179.4	181	179.4	222.3	196.9			222.3	196.9						680	
	M	184.2	117.8	184.2	177.8	203.2	177.8	222.3	196.9											
	N	209.6	196.9	209.6	196.9	222.3	196.9	222.3	196.9											
	P	228.6	181	228.6	181	254	225.4	254	225.4											
	Q	228.6	181	254	181	254	225.4	254	225.4											
6" x 8"	R	241.3	239.7	241.3	239.7	241.3	239.7												700	
	Q	241.3	239.7	241.3	239.7															
6" x 10"	R					266.7	239.7												700	
8" x 10"	T	279.4	276.2	279.4	276.2														1000	

approximate dimensions to be confirmed at order

Valves can be manufactured with materials different than those in this table upon request and after Besa Technical Dept. approval.

Pressione di taratura P / Set pressure P	ORIFIZIO D / ORIFICE D			ORIFIZIO E / ORIFICE E			ORIFIZIO F / ORIFICE F			ORIFIZIO G / ORIFICE G		
	acqua/ water	aria/ air	vapore d'acqua sat. / sat. steam	acqua/ water	aria/ air	vapore d'acqua sat. / sat. steam	acqua/ water	aria/ air	vapore d'acqua sat. / sat. steam	acqua/ water	aria/ air	vapore d'acqua sat. / sat. steam
	a 25°C kg/h	a 25°C kg/h	kg/h	a 25°C kg/h	a 25°C kg/h	kg/h	a 25°C kg/h	a 25°C kg/h	kg/h	a 25°C kg/h	a 25°C kg/h	kg/h
1	2465	107	69	4375	191	123	6875	300	193	11285	491	316
2	3486	170	108	6187	303	192	9723	474	301	15959	778	494
3	4270	250	158	7578	446	281	11908	699	440	19546	1145	722
4	4931	316	198	8750	563	352	13750	882	552	22570	1446	905
5	5513	381	237	9783	679	422	15373	1064	661	25234	1744	1083
6	6039	446	275	10717	794	489	16841	1244	767	27642	2039	1257
7	6523	511	313	11575	910	558	18190	1425	874	29857	2335	1433
8	6973	575	352	12375	1024	627	19446	1604	982	31919	2630	1610
9	7396	640	390	13125	1140	695	20625	1785	1089	33855	2926	1786
10	7796	705	429	13835	1255	764	21741	1965	1197	35686	3221	1963
12	8540	836	506	15156	1489	901	23816	2332	1411	39092	3823	2313
14	9224	966	583	16370	1721	1038	25724	2695	1626	42224	4417	2665
16	9861	1096	660	17500	1952	1176	27501	3057	1841	45140	5011	3081
18	10459	1226	737	18562	2184	1312	29169	3420	2055	47878	5606	3369
20	11025	1360	814	19566	2422	1450	30747	3793	2271	50468	6217	3722
22	11563	1491	889	20521	2655	1583	32247	4158	2479	52931	6815	4064
24	12078	1622	966	21433	2888	1720	33681	4523	2694	55285	7414	4416
26	12571	1757	1044	22309	3129	1859	35056	4900	2912	57542	8032	4773
28	13045	1888	1122	23151	3362	1998	36380	5264	3129	59714	8628	5128
30	13503	2024	1200	23963	3604	2137	37657	5645	3347	61810	9252	5485
35	14585	2354	1391	25883	4192	2477	40674	6564	3880	66763	10759	6359
40	15592	2691	1583	27670	4791	2820	43482	7503	4416	71372	12298	7237
45	16538	3028	1776	29349	5392	3162	46120	8444	4952	75702	13840	8116
50	17432	3367	1969	30937	5996	3507	48615	9390	5491	79797	15390	9001
55	18283	3708	2170	32446	6603	3865	50987	10341	6052	83691	16949	9919
60	19096	4060	2359	33889	7230	4201	53255	11322	6579	87413	18557	10783
70	20626	4750	2742	36605	8459	4883	57521	13246	7647	94417	21711	12533
80	22051	5447	3154	39132	9699	5616	61493	15188	8794	100936	24893	14414
90	23388	6156	3575	41506	10962	6366	65223	17166	9969	107058	28135	16339
100	24653	6862	3988	43751	12219	7101	68751	19134	11120	112849	31361	18226
110				45886	13499	7871	72107	21139	12326	118357	34646	20203
120				47927	14790	8651	75313	23160	13548	123620	37959	22204
130				49884	16051	9424	78389	25136	14757	128668	41197	24187
140				51767	17351	10235	81348	27171	16027	133525	44534	26269
150				53584	18660	11123	84203	29220	17418	138212	47892	28549
200				61873	25193		97229	39451		159593	64659	
250				69176	31678							

Pressione di taratura P / Set pressure P	ORIFIZIO H / ORIFICE H			ORIFIZIO J / ORIFICE J			ORIFIZIO K / ORIFICE K			ORIFIZIO L / ORIFICE L		
	acqua/ water	aria/ air	vapore d'acqua sat. / sat. steam	acqua/ water	aria/ air	vapore d'acqua sat. / sat. steam	acqua/ water	aria/ air	vapore d'acqua sat. / sat. steam	acqua/ water	aria/ air	vapore d'acqua sat. / sat. steam
	a 25°C kg/h	a 25°C kg/h	kg/h	a 25°C kg/h	a 25°C kg/h	kg/h	a 25°C kg/h	a 25°C kg/h	kg/h	a 25°C kg/h	a 25°C kg/h	kg/h
1	17570	766	494	28820	1257	810	41181	1796	1157	63925	2788	1796
2	24847	1213	771	40758	1989	1265	58239	2842	1808	90403	4411	2805
3	30432	1787	1126	49918	2930	1846	71328	4186	2638	110721	6497	4115
4	35140	2255	1411	57640	3697	2314	82363	5283	3307	127850	8199	5132
5	39287	2720	1689	64443	4460	2770	92084	6372	3958	142940	9889	6143
6	43037	3181	1961	70594	5215	3215	100873	7452	4593	156583	11565	7129
7	46485	3642	2236	76251	5972	3666	108956	8533	5238	169129	13243	8129
8	49695	4102	2512	81515	6726	4119	116478	9611	5885	180807	14915	9133
9	52709	4565	2785	86460	7484	4567	123544	10963	6525	191774	16595	10127
10	55561	5025	3062	91137	8238	5020	130227	11771	7173	202148	18268	11132
12	60863	5963	3608	99835	9776	5916	142656	13968	8453	221442	21677	13119
14	65740	6889	4157	107835	11295	6816	154086	16138	9739	239185	25045	15115
16	70279	7816	4708	115280	12815	7719	164725	18311	11029	255699	28417	17116
18	74542	8745	5255	122273	14337	8615	174718	20485	12310	271210	31792	19104
20	78574	9697	5806	128887	15899	9519	184168	22717	13601	285880	35255	21107
22	82410	10630	6338	135178	17428	10392	193158	24901	14848	299834	38645	23043
24	86074	11563	6888	141189	18958	11293	201746	27088	16136	313166	42038	25042
26	89589	12528	7444	146954	20539	12205	209984	29347	17439	325954	45544	27064
28	92971	13458	7999	152501	22065	13114	217911	31527	18738	338258	48927	29079
30	96234	14431	8556	157854	23659	14027	225559	33804	20042	350131	52465	31104
35	103944	16781	9919	170501	27513	16262	243632	39311	23235	378184	61007	36059
40	111121	19182	11288	182274	31448	18508	260454	44934	26444	404296	69733	41039
45	117862	21587	12659	193330	35391	20755	276253	50567	29655	428821	78476	46023
50	124237	24005	14039	203788	39356	23017	291196	56232	32887	452017	87266	51038
55	130301	26436	15472	213735	43341	25366	305409	61926	36243	474079	96104	56246
60	136095	28945	16819	223239	47455	27575	318989	67803	39399	495159	105225	61144
70	146999	33863	19549	241125	55519	32050	344548	79325	45794	534833	123105	71067
80	157149	38827	22483	257774	63657	36861	368337	90953	52667	571761	141151	81734
90	166682	43884	25485	273410	71947	41782	390680	102798	59698	606444	159534	92646
100	175698	48915	28428	288200	80196	46608	411813	114584	66593	639248	177824	103346
110	184273	54039	31511	302267	88597	51663						
120	192467	59206	34633	315707	97068	56781						
130	200326	64257	37726	328598	105349	61851						
140	207888	69461	40972	341003	113881	67174						
150	215185	74699	44529	352971	122468	73005						
200	248474	100851		407576	165345							

Nota 1: le portate sono state calcolate secondo le formule indicate dalla norma API RP 520 e con una sovrappressione pari al 10% della pressione di taratura p (0.1 bar se p < 1 barg).  
Nota 2: i valori intermedi possono essere approssimativamente ricavati per interpolazione lineare.  
Nota 3: le portate indicate nella presente tabella non vincolano in alcun modo BESA, la quale si riserva di eseguire sempre il dimensionamento fluidodinamico di ogni valvola di sicurezza, indicando il valore della portata calcolata sui documenti applicabili (Specifiche di prodotto nel caso di offerta; Certificato di collaudo nel caso di ordine; modulo di calcolo ove applicabile)

Note 1) Flow rates have been calculated according to API RP 520 rules with overpressure 10% (0,1 bar if p < 1 barg)  
Note 2) Approximate intermediate values can be obtained by linear interpolation  
Note 3) Flow rates given in this table are undemanding; Besa will always check fluid mechanical sizing of each safety valve, and indicate calculated flow rate in every relevant document (Specification sheet in case of offer, inspection certificate in case of order, calculation sheet when applicable)

Pressione di taratura P / Set pressure P	ORIFIZIO M / ORIFICE M			ORIFIZIO N / ORIFICE N			ORIFIZIO P / ORIFICE P			ORIFIZIO Q / ORIFICE Q		
	acqua/ water	aria/ air	vapore d'acqua sat. / sat. steam	acqua/ water	aria/ air	vapore d'acqua sat. / sat. steam	acqua/ water	aria/ air	vapore d'acqua sat. / sat. steam	acqua/ water	aria/ air	vapore d'acqua sat. / sat. steam
	a 25°C kg/h	a 25°C kg/h	a 25°C kg/h	a 25°C kg/h	a 25°C kg/h	a 25°C kg/h	a 25°C kg/h	a 25°C kg/h	a 25°C kg/h	a 25°C kg/h	a 25°C kg/h	a 25°C kg/h
1	80661	3518	2267	97224	4241	2733	142919	6234	4017	247539	10798	6958
2	114072	5567	3540	137496	6712	4268	202118	9865	6274	350074	17087	10866
3	139709	8198	5167	168397	9917	6229	247544	14527	9156	428751	25162	15859
4	161322	10346	6476	194448	12473	7807	285839	18334	11476	495079	31755	19877
5	180364	12479	7751	217400	15045	9345	319577	22113	13736	553515	38302	23792
6	197579	14594	8995	238149	17595	10845	350079	25861	15941	606345	44793	27610
7	213410	16711	10258	257231	20147	12367	378129	29613	18177	654928	51291	31484
8	228144	18821	11525	274991	22691	13895	404237	33352	20423	700147	57766	35373
9	241984	20941	12816	291672	25247	15452	428758	37109	22712	742618	64274	39338
10	255073	23052	14047	307449	27792	16935	451951	40849	24892	782788	70753	43114
12	279419	27354	16554	336794	32979	19958	495087	48473	29335	857502	83956	50809
14	301807	31604	19072	363779	38103	22995	534755	56004	33798	926207	97001	58539
16	322645	35858	21598	388896	43232	26039	571677	63543	38273	990157	110058	66291
18	342217	40117	24106	412487	48366	29064	606355	71089	42718	1050221	123129	73990
20	360728	44487	26634	434799	53635	32111	639155	78833	47198	1107030	136542	81749
22	378335	48764	29077	456021	58792	35057	670351	86413	51527	1161063	149671	89247
24	395158	53046	31599	476299	63954	38097	700159	94001	55996	1212690	162813	96988
26	411293	57470	34151	495747	69287	41174	728749	101840	60518	1262208	176390	104819
28	426819	61739	36694	514461	74435	44240	756258	109406	65024	1309855	189494	112625
30	441800	66199	39249	532518	79812	47320	782802	117309	69552	1355829	203182	120466
35	477198	76982	45501	575185	92812	54858	845522	136416	80631	1464463	236278	139656
40	510146	87993	51785	614899	106087	62434	903901	155929	91766	1565576	270074	158942
45	541092	99025	58074	652199	119388	70016	958732	175479	102911	1660545	303935	178245
50	570361	110117	64403	687478	132761	77646	1010592	195135	114126	1750368	337980	197670
55	598200	121269	70975	721033	146206	85570						
60	624799	132778	77155	753094	160082	93021						
70	674860	155341	89677	813435	187284	108117						
80	721456	178112	103136	869598	214738	124344						
90	765220	201308	116906	922348	242704	140946						

Pressione di taratura P / Set pressure P	ORIFIZIO R / ORIFICE R			ORIFIZIO T / ORIFICE T		
	acqua/ water	aria/ air	vapore d'acqua sat. / sat. steam	acqua/ water	aria/ air	vapore d'acqua sat. / sat. steam
	a 25°C kg/h	a 25°C kg/h	a 25°C kg/h	a 25°C kg/h	a 25°C kg/h	a 25°C kg/h
1	358444	15635	10075	582441	25408	16373
2	506917	24742	15735	823697	40206	25570
3	620844	36435	22963	1008818	59208	37317
4	716888	45980	28781	1164883	74720	46771
5	801506	55460	34450	1302379	90125	55983
6	878005	64859	39979	1426684	105400	64968
7	948354	74268	45588	1540995	120689	74084
8	1013833	83644	51219	1647393	135926	83234
9	1075333	93067	56793	1747324	151239	92292
10	1133500	102448	62428	1841842	166484	101449
12	1241687	121567	73571	2017636	197552	119556
14	1341175	140455	84764	2179296	228246	137745
16	1433777	159362	95987	2329766	258970	155984
18	1520750	178288	107136	2471090	289726	174101
20	1603011	197709	118370	2604757	321287	192357
22	1681252	216720	129227	2731893	352180	210000
24	1756011	235749	140436	2853369	383104	228215
26	1827714	255408	151775	2969880	415050	246642
28	1896709	274383	163077	3081991	445885	265009
30	1963280	294202	174432	3190163	478093	283460

Nota 1: le portate sono state calcolate secondo le formule indicate dalla norma API RP 520 e con una sovrappressione pari al 10% della pressione di taratura p (0,1 bar se p < 1 barg).  
 Nota 2: i valori intermedi possono essere approssimativamente ricavati per interpolazione lineare.  
 Nota 3: le portate indicate nella presente tabella non vincolano in alcun modo BESA, la quale si riserva di eseguire sempre il dimensionamento fluidodinamico di ogni valvola di sicurezza, indicando il valore della portata calcolata sui documenti applicabili (Specifiche di prodotto nel caso di offerta; Certificato di collaudo nel caso di ordine; modulo di calcolo ove applicabile)

Note 1) Flow rates have been calculated according to API RP 520 rules with overpressure 10% (0,1 bar if p < 1 barg)  
 Note 2) Approximate intermediate values can be obtained by linear interpolation  
 Note 3) Flow rates given in this table are undemanding; BESA will always check fluid mechanical sizing of each safety valve, and indicate calculated flow rate in every relevant document (Specification sheet in case of offer, inspection certificate in case of order, calculation sheet when applicable)

Il diagramma rappresenta la tendenza del coefficiente di efflusso Kd, secondo il rapporto pb/p0 (aeriformi)

Diagram showing coefficient of discharge Kd trend vs. pb/p0 ratio (gaseous)

pb= contropressione (bar a)  
 po= pressione di scarico (bar a)

pb= backpressure (bar abs)  
 po= upstream relieving pressure (bar abs)

